

# AOM4

## Programmable Excitation Module

---

The AOM4 Programmable Excitation Module provides four channels of high-speed analog voltage output. Each channel has an independent D/A converter.

The D/A converters offer true 12-bit resolution with a maximum nonlinearity of  $\pm .012\%$ . A single 0-10.2375V output range has a resolution of 2.5mV and a maximum output current of 40mA.

Each output stage can be supplied either by the internal +15V supply, or by an external supply of +15 (+2, -0) VDC.

A system strobe feature, supported by two levels of data latching in the D/A converters, allows any number of D/A channels to be updated simultaneously.

Signals are connected directly to the module via screw terminals mounted on the right-hand side of the module board.

The AOM4 module may be placed in any available slot in the system. To install the module, first turn off power and remove the top cover of the mainframe. Insert the module in the desired slot with the component side facing the power supply. Generally, analog modules should be placed in the low-numbered slots to isolate them from power supply thermal and noise effects.

**CAUTION: Always turn off the system power before installing or removing modules. To avoid possible EMI radiation never operate the system with the top cover removed.**

### User-Configured Components

All output connections are made to screw terminals located on the module. Two terminals are provided for each channel: signal output and common ground.

**Table 1. User-Configured Components on the AOM4**

<u>Name</u>	<u>Designation</u>	<u>Function</u>
Screw Terminals	J171	Output Connection Channels 0-3
	Part of J171	External Power Connections
Jumper 101	W101	Select Internal/External Supply

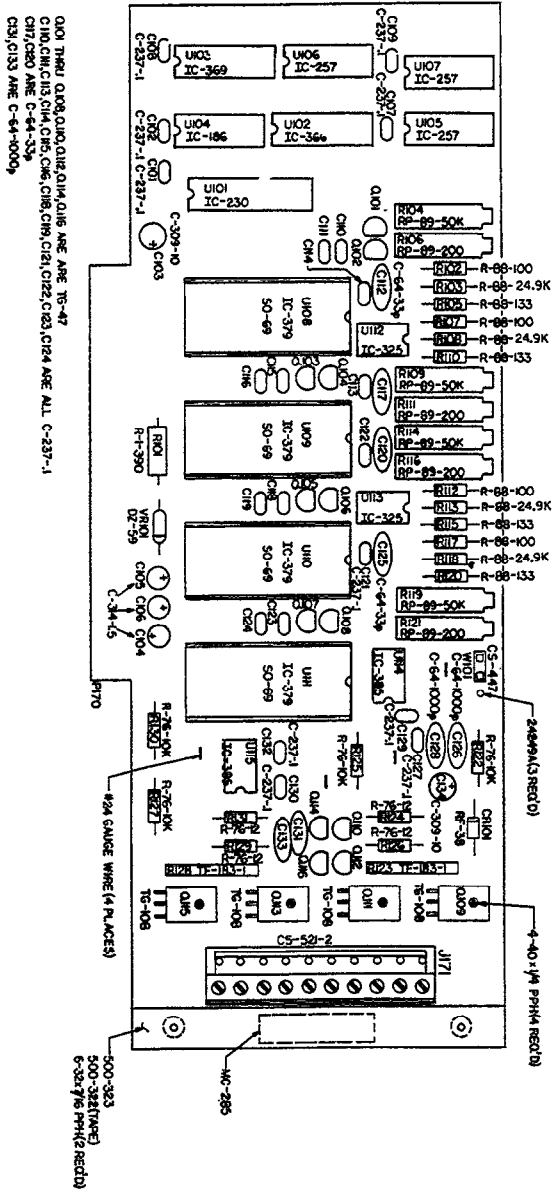
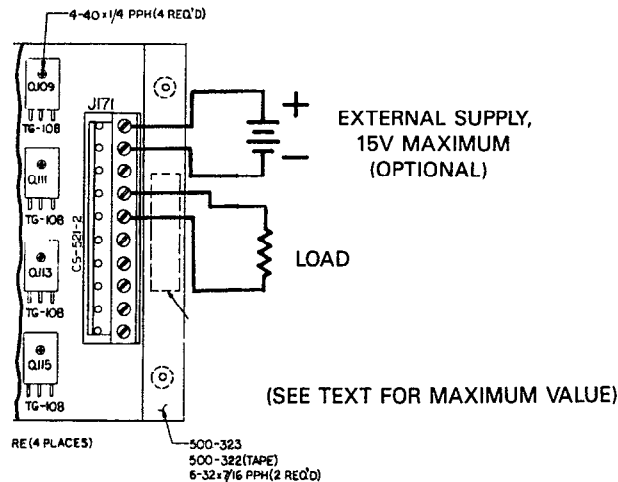

Figure 1. AOM4 Module

## Connections

Terminal connections are shown in Figure 2, which illustrates a typical connecting scheme. The use of shielded cable is recommended to minimize the possibility of EMI radiation. Connect one end of the shield to AOM4 ground and leave the other end disconnected.



**Figure 2. Typical AOM4 Output Connections (Channel 0 shown)**

## Voltage Supply Connections

The channel outputs may be operated from either the internal +15V supply or an external supply of +15 (+2, -0) VDC. When using the internal supply, jumper W101 must be in the INT position. To operate the module on an external supply, place W101 in the EXT position and connect the supply to the external supply terminals. Be sure to observe proper polarity.

## Output Loading Considerations

Each channel on the AOM4 card can supply a maximum of 10.2375V at 40mA. Thus there is a minimum resistance value that can be connected across the outputs without loading them down. With the above voltage and current values, the minimum recommended load resistance is 256Ω. Note that the outputs are short circuit protected, so that lower resistance values will not damage the module, but they will affect output accuracy. However, the maximum recommended load capacitance is 0.1μF. Exceeding this value may cause the output channel to oscillate.

## Commands

AOM4 module commands are listed in Table 2. Table 3 summarizes the locations for slot-dependent commands.

**Table 2. Commands Used with the AOM4 Module**

<b>Command</b>	<b>Location</b>
D/A CONTROL	Slot-dependent CMDA
D/A DATA	Slot-dependent CMDB
STROBE	CFF9D

**Table 3. Locations of Slot-dependent Commands**

<b>Slot</b>	<b>CMDA</b>	<b>CMDB</b>
Slot 1	CFF80	CFF81
Slot 2	CFF82	CFF83
Slot 3	CFF84	CFF85
Slot 4	CFF86	CFF87
Slot 5	CFF88	CFF89
Slot 6	CFF8A	CFF8B
Slot 7	CFF8C	CFF8D
Slot 8	CFF8E	CFF8F
Slot 9	CFF90	CFF91
Slot 10	CFF92	CFF93

#### **D/A CONTROL**

Location: Slot-dependent CMDA

D/A CONTROL always precedes D/A DATA, indicating to the AOM4 module which channel of analog output to update, and which byte of data to load. Table 4 lists values written to the D/A CONTROL locations.

The high and low bytes of data may be updated independently and in any order; there is no hardware reason that both bytes must be updated at the same time. Similarly, channels can be updated independently and in any order.

The location assigned to D/A CONTROL varies depending on which baseboard slot holds the D/A converter being addressed (See Table 3).

**Table 4. Values Written to D/A CONTROL**

<b>Function</b>	<b>Binary</b>	<b>Hex</b>	<b>Decimal</b>
Channel 0 low byte	0000	H0	0
Channel 0 high byte	0001	H1	1
Channel 1 low byte	0010	H2	2
Channel 1 high byte	0011	H3	3
Channel 2 low byte	0100	H4	4
Channel 2 high byte	0101	H5	5
Channel 3 low byte	0110	H6	6
Channel 3 high byte	0111	H7	7

## D/A DATA

Location: Slot-dependent CMDB

D/A DATA is used to load data values into the D/A converter. This command should always be preceded by D/A CONTROL, which selects the channel and the byte to be loaded. The data must be separated into low and high bytes prior to loading, and each byte must be prefaced by D/A CONTROL.

When the strobe feature is not enabled, the output of the converter is updated immediately. Thus, when the strobe is not used, the low and high bytes are updated independently. When the strobe is enabled, outputs are not updated until the STROBE command is issued with the value 1 (to issue data).

To determine the digital value to input for a given voltage, it is necessary to know the output range of the D/A converter. With a 12-bit digital converter, there are 4096 possible voltage levels, specified with digital values 0-4095. Therefore the actual voltage of each step equals the range divided by 4095. For an input range of 0 to 10.237V the voltage of each step is 10.237V/4095 or 2.5mV; thus a BASIC formula for each voltage value can be derived:

$$V = D \times 2.5 \times 10^{-3}$$

Where V is voltage and D is the digital value in counts loaded into the converter. Similarly, the following BASIC equation determines the digital value to use when a particular voltage is required:

$$D = \text{INT} \left( \frac{V}{2.5 \times 10^{-3}} \right)$$

Again, D is the digital value, while V is the voltage.

The digital values may be separated into low byte (LB) and high byte (HB) values with the following equations:

$$\begin{aligned} \text{HB} &= \text{INT} (D/256) \\ \text{LB} &= (D/256 - \text{HB}) * 256 \end{aligned}$$

## STROBE

Location: CFF9D

The STROBE command is used to make possible the synchronous updating of two or more analog output channels. STROBE is issued in three modes: strobe enable, strobe disable and issue data. The STROBE feature must either be enabled or disabled at the start of any program, or the D/A converters will not function (see Table 5).

When any strobe feature is disabled, all data given to a D/A converter is immediately placed in that converter's primary data latch, and the current output updated. The low byte and high byte are thus updated asynchronously.

When the strobe is enabled, no data is updated until the STROBE command has been issued in the issue data mode. New data is placed in a secondary data latch within the D/A converter. When the STROBE command (to issue data) is given, new data is released to the primary data latch, updating the voltage output, and old data in other channels is reissued, leaving the voltage output of these channels unchanged. The strobe is completely flexible. Any amount of data from a single byte to any number of channels can be updated when the strobe is enabled.

To use the strobe, issue the strobe enable command early in the program. Use the D/A CONTROL and D/A DATA commands to load the secondary latches of the appropriate converters. This can be done as far in advance as required. To issue the new data, load STROBE with 1 (to issue data), releasing all data loaded since the last issue data command and leaving unchanged the outputs of other channels.

The STROBE feature is global, affecting all D/A modules installed in the Series 500 simultaneously.

**Table 5. Values Written to STROBE**

<b>Function</b>	<b>Binary</b>	<b>Hex</b>	<b>Decimal</b>
Strobe Enable	01000000	H40	64
Strobe Disable	10000000	H80	128
Issue Data	00000001	H01	1

## **AOM4 Module Calibration**

Calibration of the AOM4 module is very similar to the procedure used to calibrate the AOM1. This module has only a single range, however, so the complexity is reduced considerably. Figure 3 shows calibration adjustment locations for the AOM4. Program 1 lists a calibration program intended for use with this module.

1. Place the module to calibrated in slot 5 of the system baseboard.
2. Unless an external voltage source is connected to the module, place the supply jumper in the internal position.
3. Connect the DMM high (or current input) lead to the signal output terminal of the channel being calibrated. Connect the DMM low signal lead to module ground.
4. Select an appropriate function and range on the DMM. Remember that the AOM4 output signal is a voltage in the range of 0 to +10.2375V.
5. Enter program 1 into the computer.
6. Run the program and follow the instructions given. The program will prompt for module type and output channel, and then display the correct offset and gain adjustment values in that order.

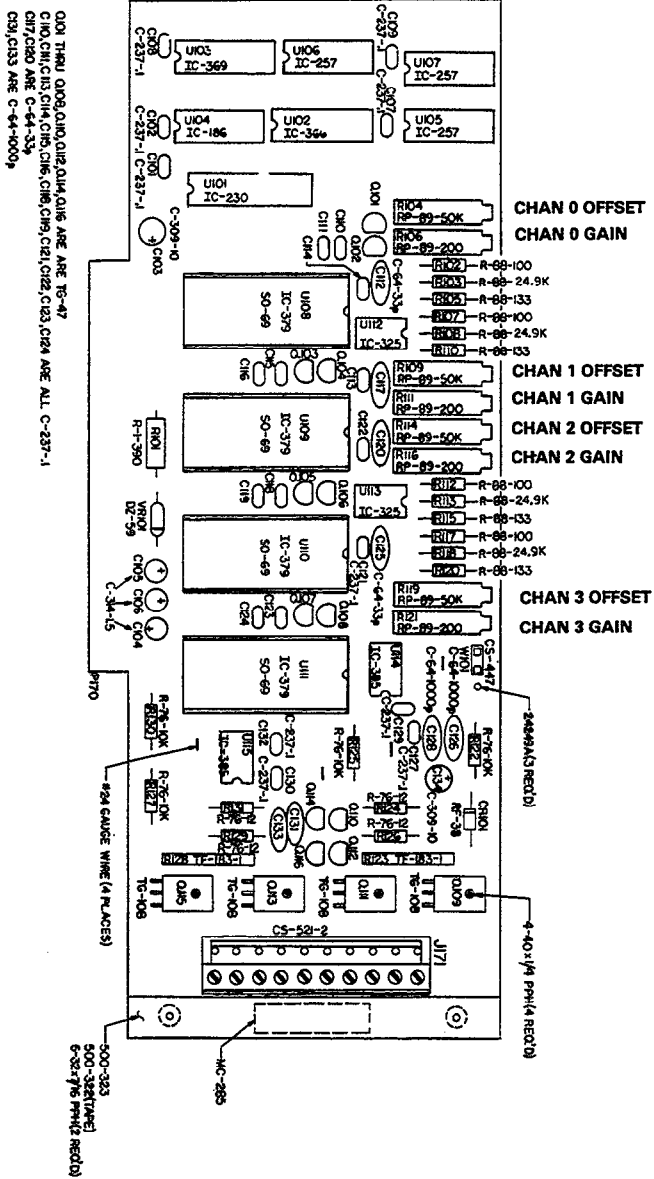

Figure 3. AOM4 Calibration Adjustments

### Program 1. AOM4 Calibration

```
10 DEF SEG=&HCFF0:CLS
20 CA=&H88:CB=&H89:ST=&H9D
30 POKE ST,64
40 PRINT"1-AOM3"
50 PRINT"2-AOM4"
60 PRINT:INPUT "MODULE TYPE (1 OR 2)";M
70 IF M<1 OR M>2 THEN 60
80 IF M=1 THEN M$="AOM3":R$="CURRENT"
90 IF M=2 THEN M$="AOM4":R$="VOLTAGE"
100 PRINT "INSERT";M$:"INTO SLOT 5"
110 PRINT:INPUT "CHANNEL (0-3)";CH
120 IF CH<0 OR CH>3 THEN 110
130 PRINT:PRINT "CONNECT DMM TO CHANNEL";CH
140 PRINT "SET DMM TO MEASURE";R$
150 ON M GOSUB 300,320
160 POKE CA,2*CH:POKE CB,LB
170 POKE CA,2*CH+1:POKE CB,HB
180 POKE ST,1
190 PRINT:PRINT"ADJUST CHANNEL";CH;"OFFSET FOR"; L$;"READING ON DMM"
200 INPUT "PRESS RETURN TO CONTINUE";A$
210 ON M GOSUB 310,330
220 POKE CA,2*CH:POKE CB,LB
230 POKE CA,2*CH+1:POKE CB,HB
240 POKE ST,1
250 PRINT:PRINT"ADJUST CHANNEL";CH;"GAIN FOR";H$; "READING ON DMM"
260 INPUT"PRESS RETURN TO CONTINUE";A$
270 PRINT:INPUT"AGAIN";A$
280 IF LEFT$(A$,1)="Y" THEN 110
290 END
300 LB=1:HB=0:L$="5μA":RETURN
310 LB=255:HB=15:H$="20.475mA":RETURN
320 LB=1:HB=0:L$="2.5mV":RETURN
330 LB=255:HB=15:H$="10.238V":RETURN
```

## Theory of Operation

The AOM4 schematic is located on drawing number 500-416.

The circuitry on the module can be divided into three groups: D/A conversion circuitry for each of the four channels, command development circuitry, and data buffering circuitry.

D/A conversion centers around the complete 12-bit D/A converters (AD567JN), one for each channel of the module. These converter ICs are designated U108 through U111 for channels 0 to 3 respectively. The converters contain precision voltage references, high speed analog switches, two levels of data latching, and a precision resistor ladder. Each D/A converter is supplemented by a high-speed, high accuracy, operational amplifier, U112A and U112B for channels 0 and 1, and U113A and U113B for channels 2 and 3 respectively.

Two potentiometers calibrate the gain and offset for each D/A converter: potentiometers R106, R111 and R121 calibrate the gain for channels 0-3 respectively. Transistors Q109,



Q111, Q113 and Q115 are the output transistors for channels 0-3, while Q110, Q112, Q114 and Q116 provide short circuit protection for those channels, Each op amp has a 0.001uF capacitor in the feedback loop to prevent oscillation with large capacitive loads.

Components U102-U107 comprise the command development circuitry. A quad transparent data latch, U102 (74LS75) stores the 3 bit command selected data (a number between 0 and 7). This latch is refreshed by a negative pulse of the D/A CONTROL command line (CMDA). CMDA is buffered and inverted by a hex inverter segment of U104 (74LS04). U103, a binary-to-decimal decoder (74LS42), generates eight separate command lines based on the 3 bit binary word from U102. The eight command lines are then gated by quad OR gate segments of U105-U107 to control data latching in U108-U111.

The eight data lines are buffered by U101, an octal buffer (74LS244). The operation of U101 is controlled by the CMDA and CMDB lines through elements of U104 and U105. U101 will be enabled if either CMDA or CMDB is low.

## **AOM4 Specifications**

Number of Channels: 4  
Range of Output: 0 to 10.2375V  
Resolution: 12 bits  
Maximum Output Current: 40mA

The AOM4 consists of 4 voltage-output channels. Each channel has a nominal output voltage range of 0 to 10.2375V with 12-bit resolution. This corresponds to 2.5mV per LSB. The output power supply can be provided either by the internal +15V supply or by an external +15V supply. The output stage is short-circuit protected and can drive a capacitive load of up to .1μF.



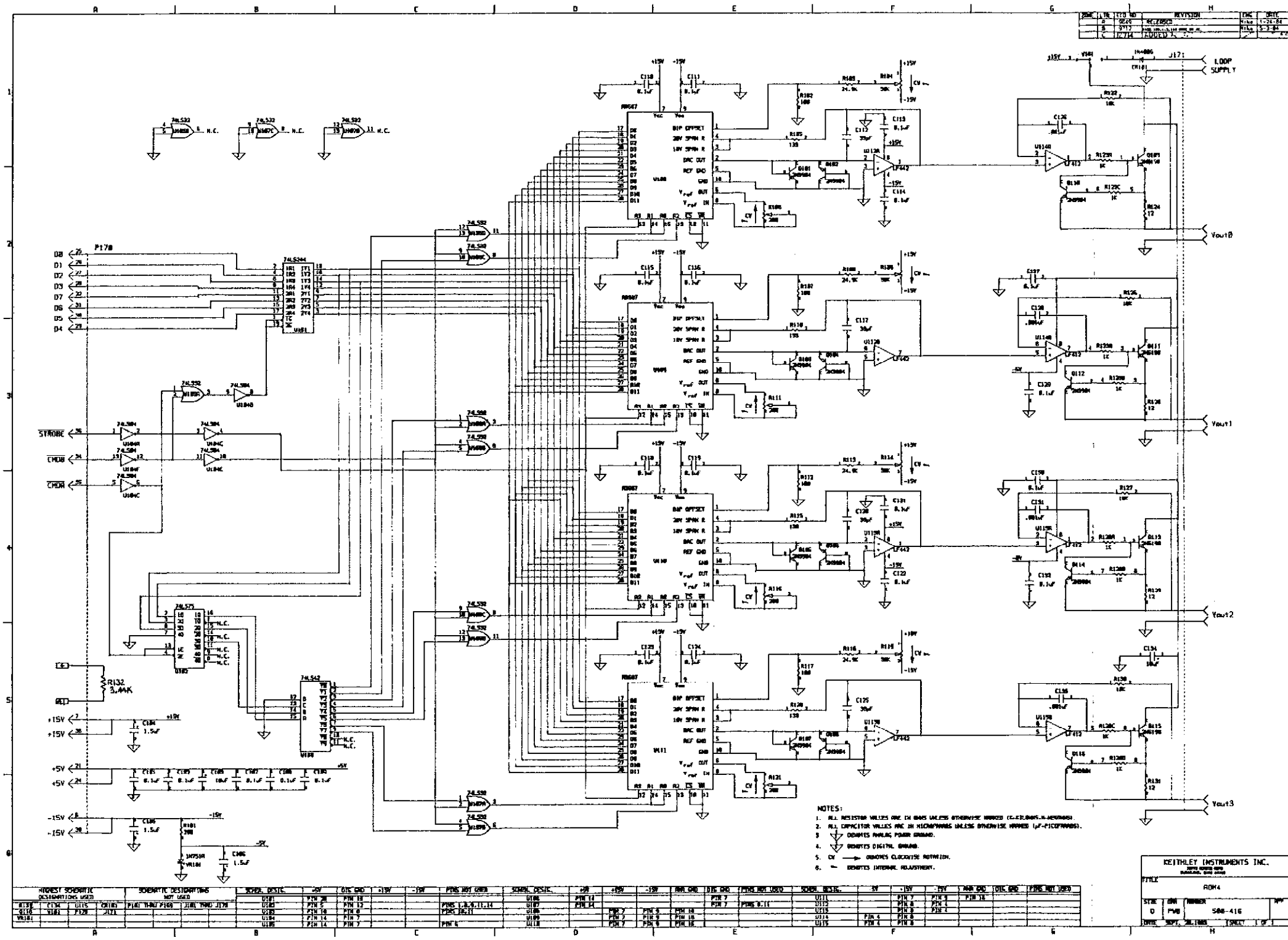

- NOTES:
1. ALL RESISTOR VALUES ARE IN OHMS UNLESS OTHERWISE INDICATED (E.G. 10K, 100K, 1M).
  2. ALL CAPACITOR VALUES ARE IN PICOFARADS UNLESS OTHERWISE INDICATED (E.G. 10P, 100P, 1N).
  3. □ DENOTES PULL-UP POINTS.
  4. □ DENOTES DIGITAL GROUND.
  5. CV DENOTES CLOCKWISE ROTATION.
  6. □ DENOTES INTERNAL JEDEC MOUNTING.

IC PART NUMBER	IC PART NUMBER	IC PART NUMBER	IC PART NUMBER	IC PART NUMBER	IC PART NUMBER	IC PART NUMBER	IC PART NUMBER	IC PART NUMBER	IC PART NUMBER	IC PART NUMBER	IC PART NUMBER	IC PART NUMBER	IC PART NUMBER	IC PART NUMBER	IC PART NUMBER	IC PART NUMBER	IC PART NUMBER	IC PART NUMBER	IC PART NUMBER	IC PART NUMBER
74LS244	74LS244	74LS244	74LS244	74LS244	74LS244	74LS244	74LS244	74LS244	74LS244	74LS244	74LS244	74LS244	74LS244	74LS244	74LS244	74LS244	74LS244	74LS244	74LS244	74LS244

KEITHLEY INSTRUMENTS INC.  
 2200 CALIFORNIA AVENUE  
 BERKELEY, CALIF. 94704  
 MODEL 506-416  
 DATE 11/11/71

AOM4 SCHEMATIC DIAGRAM